



BATTERY CHARGER & JUMP STARTER

RACBC2IN1

USER GUIDE

CAUTION: Read this manual before using this machine!

CONTENTS

1. SAFETY INSTRUCTIONS.....	3
2. DESCRIPTION.....	6
3. OPERATION.....	6
4. MAINTENANCE AND STORAGE.....	10
5. TECHNICAL SPECIFICATIONS.....	10
6. SYMBOLS EXPLANATION.....	11
7. DISPOSAL.....	11
8. DECLARATION OF CONFORMITY.....	12
9. WARRANTY.....	13
10. PRODUCT FAILURE.....	14
11. WARRANTY EXCLUSIONS.....	15

1. SAFETY INSTRUCTIONS

 **WARNING:** Read all safety warnings and all instructions. Failure to follow the warnings and instructions may result in electric shock, fire and/or serious injury. Save all warnings and instructions for future reference.

SPECIFIC SAFETY INSTRUCTIONS

- This appliance can be used by children aged from 8 years and above and persons with reduced physical, sensory or mental capabilities or lack of experience and knowledge if they have been given supervision or instruction concerning use of the appliance in a safe way and understand the hazards involved. Children shall not play with the appliance. Cleaning and user maintenance shall not be made by children without supervision.
- If the supply cord is damaged, it must be replaced by the manufacturer, its service agent or similarly qualified persons in order to avoid a hazard.
- During charging, the battery must be placed in a well-ventilated area.
- Warning: do not recharge non-rechargeable batteries.
- The battery terminal not connected to the chassis has to be connected first. The other connection is to be made to the chassis, remote from the battery and fuel line. The battery charger is then to be connected

to the supply mains.

- After charging, disconnect the battery charger from the supply mains. Then remove the chassis connection and then the battery connection.

-  For indoor use only.

- Before using battery charger, read all instructions and cautionary markings in this manual, on battery charger, battery, and product using battery to prevent misuse of the products and possible injury or damage.

-  **CAUTION:** To reduce the risk of electric shock or damage to the charger and battery, charge only BUILDER lithium-ion LFP and lead-acid AGM, GEL, STD (Min.1.2Ah, Max.400Ah) rechargeable batteries. Other types of batteries may burst, causing personal injury or damage.

- Do not use charger outdoors or expose to wet or damp conditions. Water entering charger will increase the risk of electric shock.

- Use of an attachment not recommended or sold by the battery charger manufacturer may result in a risk of fire, electric shock, or injury to persons. Following this rule will reduce the risk of electric shock, fire, or serious personal injury.

- Before using the device check that the mains cable and mains plug are not damaged.

- Do not use the device if it has suffered any heavy shock or jolting, or is damaged in any other way.

- Due to the heat generated during charging, the battery charger should not be operated on a combustible surface/in an inflammable environment.
- Do not cover the ventilating slits.
- Never disassemble the device yourself.
- Pull the plug of the battery charger out of the socket when it is not in use or when cleaning it.
- Only use extension cables that are approved and technically in perfect condition.
- During operation provide sufficient ventilation. Malfunction during charging can be caused by storing and operating in places where the temperature exceeds +40°C. this should be avoided. Battery charging in closed cupboards, near heat sources (radiators, bright sunshine) etc., causes heat to accumulate and can damage the device.
- If the battery is not going to be used for a longer period, pull the battery off the battery charger and pull out the mains plug.
- Protect battery contact to avoid a short circuit caused by metallic object that can cause a fire or explosion.
- Only charge original recommended batteries.

2. DESCRIPTION

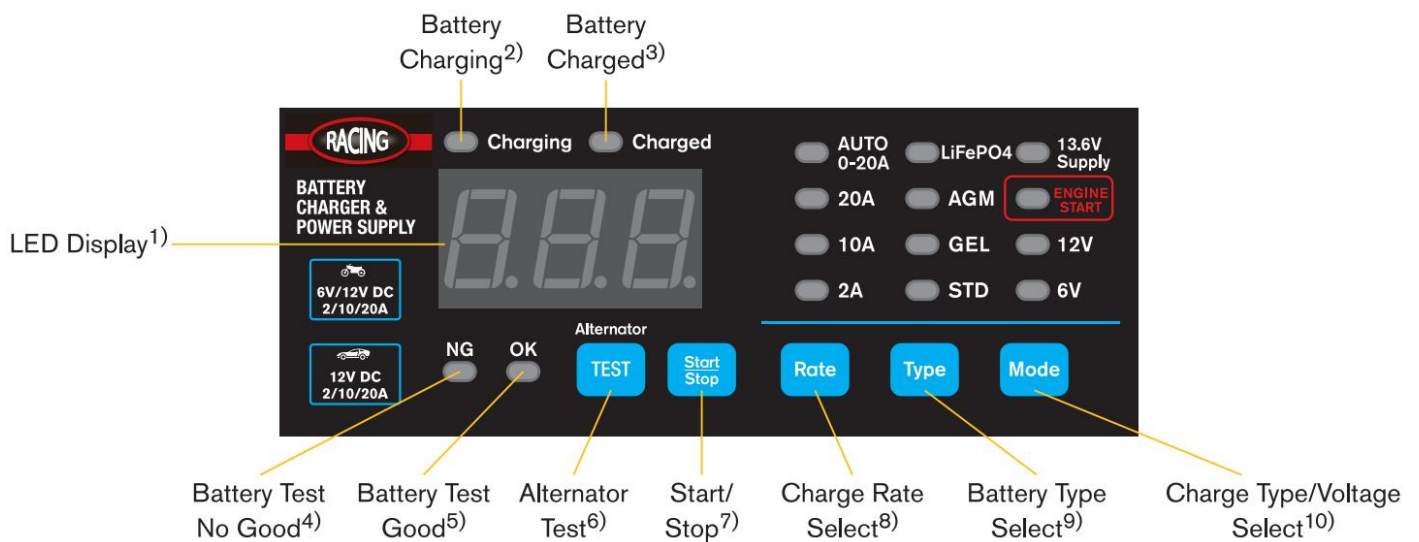
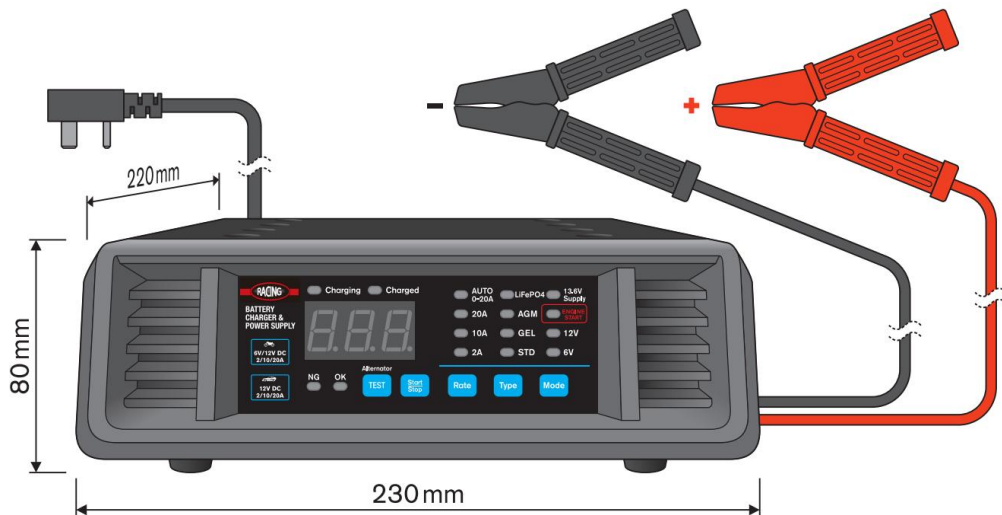

3. OPERATION



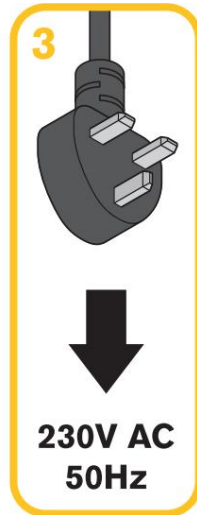
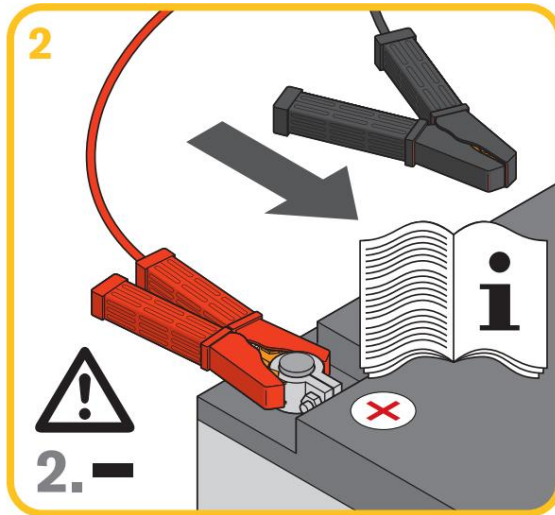
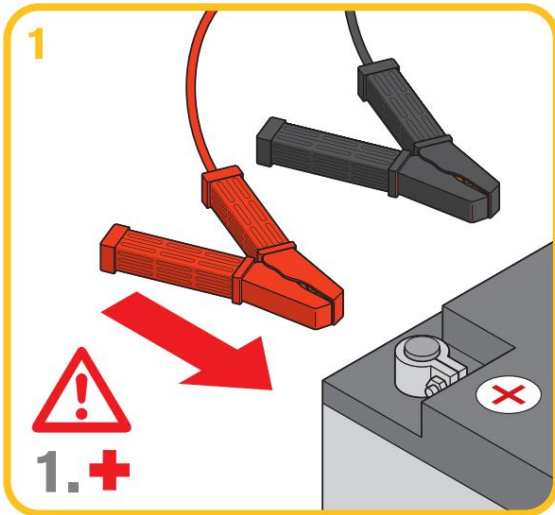
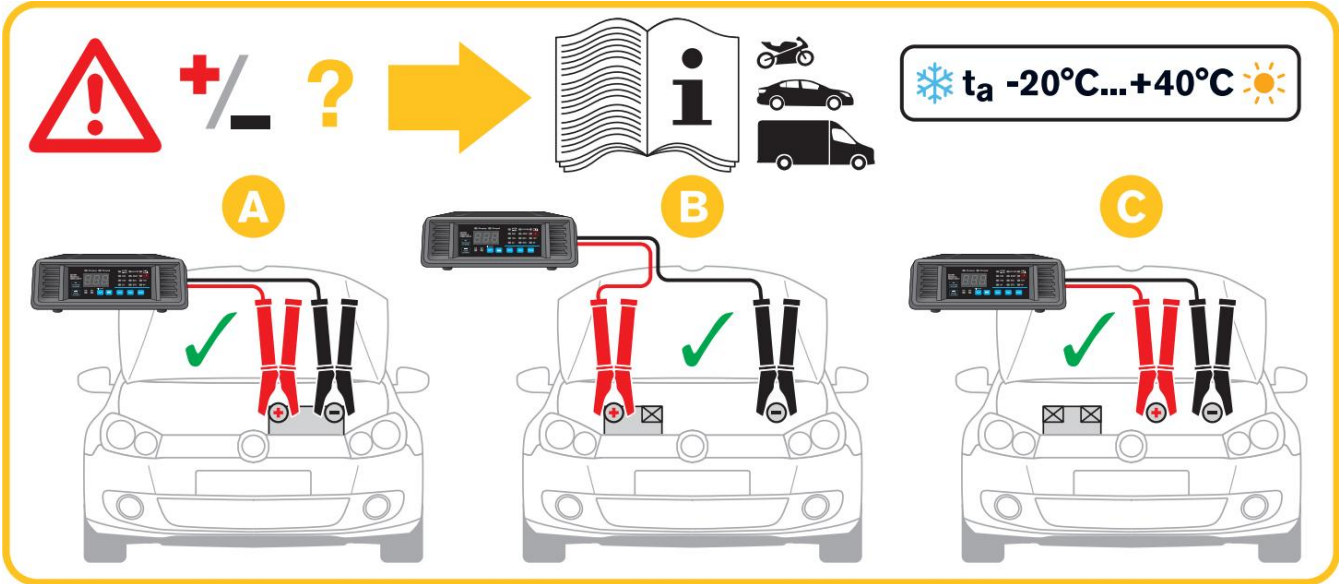

4a

1.

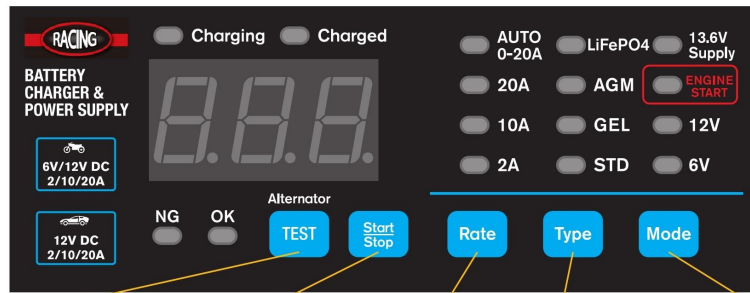
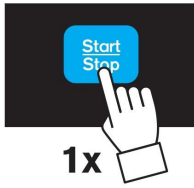

2.

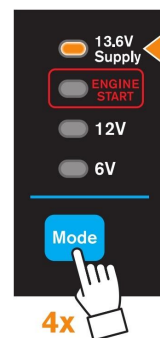
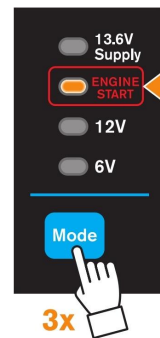
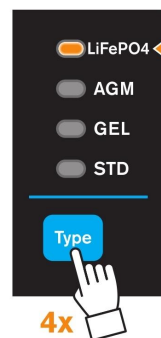
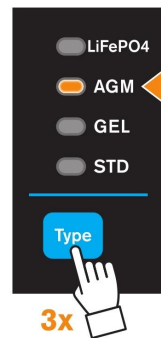
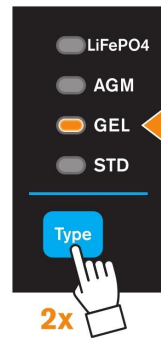
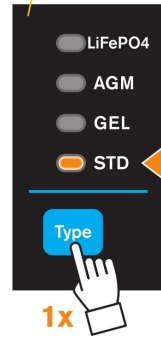
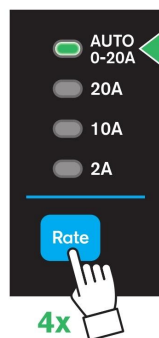
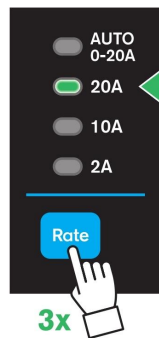
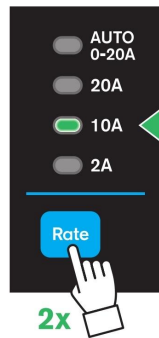
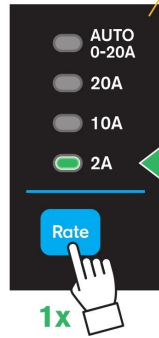
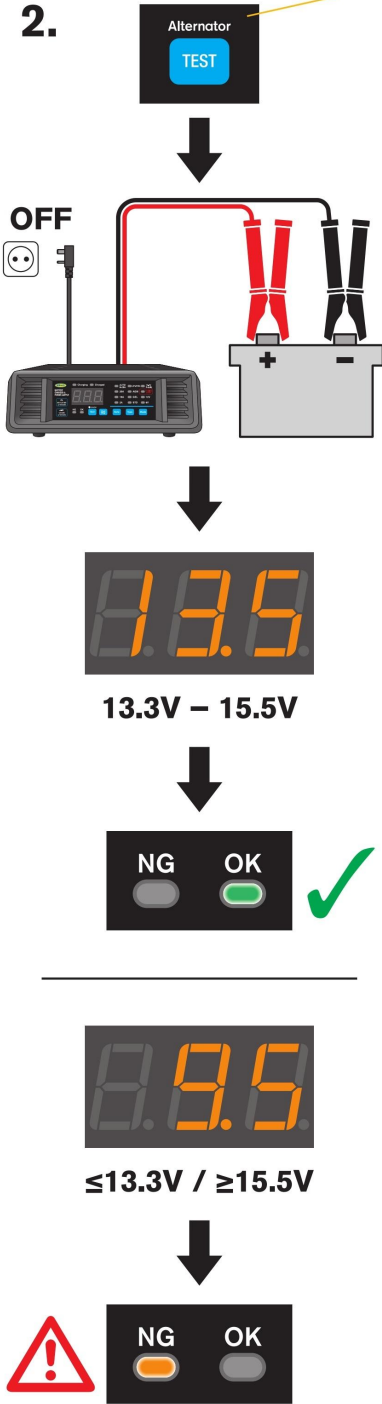

4b

Jump Start

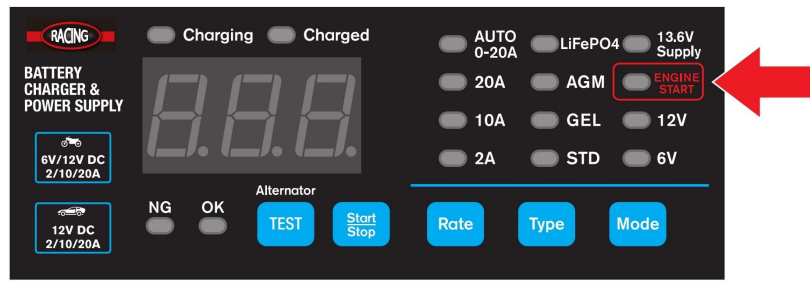
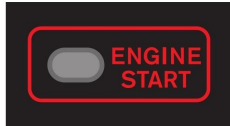

1. 1x
2. 1x
3. 1x
4. 2x
5. 1x
Charging 5 min.
6. 3x
7.
 - ≤5 sec
 - Waiting 3 min.
 - ≤5 sec

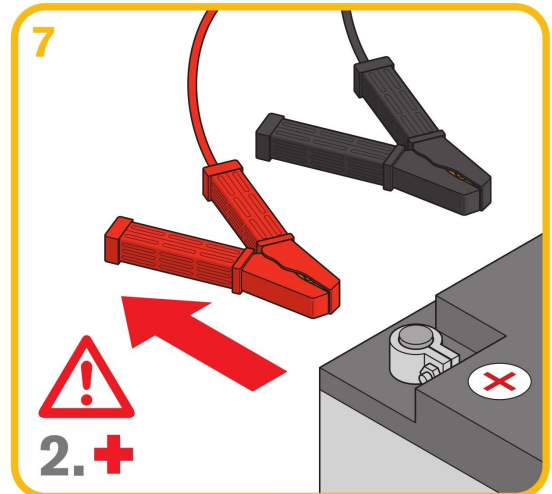
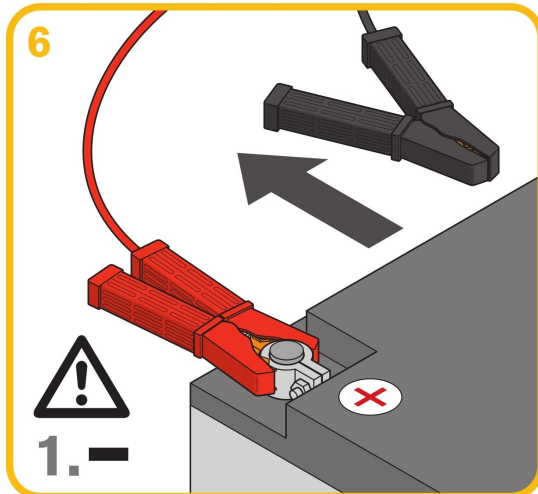
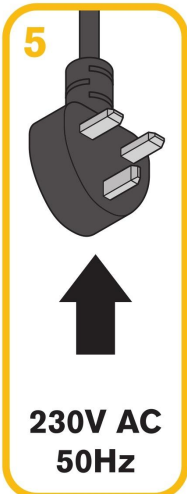

This appliance can be used by children aged from 8 years and above and persons with reduced physical, sensory or mental capabilities or lack of experience and knowledge if they have been given supervision or instruction concerning use of the appliance in a safe way and understand the hazards involved..

Children should be supervised to ensure that they do not play with the appliance. For indoor use only. Charging only rechargeable Batteries. Disconnect the supply before making or breaking the connections to the battery.

WARNING: Explosive gases. Prevent flames and sparks.

WARNING: Use of unauthorized parts or failure to follow maintenance Instructions may create a risk of electric shock or injury. Store the manual in a safe place.

DANGER! Please note that lead-acid batteries generate explosive gasses during the normal operation of the battery. For this reason, it is very important to read and follow these instructions carefully every time you use the loading device.

WARNING! Modern vehicles include numerous electronic systems. It is necessary to consult your vehicle manufacturer if there are specific instructions regarding the use of this type of device in different vehicles. Charge in a well-ventilated place. DO NOT operate near flammable liquids or gases. DO NOT touch the attached clamps or let them touch the chassis. DO NOT connect the clamps with another metal object. DO NOT cross-connect the charger's power cords to the battery. Make sure the positive terminal (+/RED) is connected to the positive terminal and the negative terminal (-/BLACK) is connected to the positive terminal. DO NOT pull cables or battery terminal clamps. DO NOT pull the power cord and DO NOT use it to carry the charger. DO NOT remove the connector from the outlet with the cable. DO NOT use cables, connectors, or clamps that are worn or damaged. Any defective part must be repaired immediately or replaced by a qualified technician. DO NOT use the loader for any task it has not been designed for. DO NOT cover or obstruct the racks or the charger cooling fan.

4. MAINTENANCE AND STORAGE

4.1 MAINTENANCE

- Service, testing and repairs should only be carried out by authorized service centers.
- From time to time the ventilation slots on the motor casing should be cleaned out. If the unit should become defective, repair should be performed by an authorized service agent.
- Avoid using solvents when cleaning plastic parts.
- Most plastics are susceptible to damage from various types of commercial solvents and may be damaged by their use. Use clean clothes to remove dirt, dust, oil, grease, etc.

 **WARNING:** Do not at any time let brake fluids, gasoline, petroleum based products, penetrating oils, etc., come in contact with plastic parts. Chemicals can damage, weaken or destroy plastic which may result in serious personal injury.







4.2 STORAGE

Store your charger in a cool dry place between 10°C & 25°C. It is not recommended to leave it in a cold works van overnight. Ensure no metal filings or swarf can fall into the vents during storage, as this may cause serious injury when it is next used.

5. TECHNICAL SPECIFICATIONS

Input	220-240V~ 50Hz 2.5A
Output	6/12Vd.c. 2/10/20A
Power supply	12V d.c. default: 13.6V d.c. 20A
Booster function	Stop for 180s boosting 5s
Start current	Max. 75A
Battery capacity	Min. 1.2Ah Max. 400Ah

6. SYMBOLS EXPLANATION

	Do not dispose of old appliances with domestic rubbish.		General warning!
	To reduce the risk of injury, the user must read and understand this manual before using this product.		Recycling.
	Conforms to relevant safety standards.		Type of fuse.
	This product is suitable for indoor use.		

7. DISPOSAL



Electric power tools, as well as their accessories and packaging, must each be able to follow an appropriate recycling pathway. Only for the countries of the European Union: Do not throw away your electrical appliance with the household waste! In accordance with the European Directive 2012/19/EU on waste electrical and electronic equipment and its implementation in national laws, power tools that can no longer be used must be separated and follow an appropriate recycling pathway.

8. DECLARATION OF CONFORMITY



BUILDER SAS

32 rue Aristide Bergès - Z.I. du Casque - 31270 Cugnaux - France

Declares that the machine indicated below:

Designation: BATTERY CHARGER & JUMP STARTER

Model: RACBC2IN1

Serial number: 20250111976-20250113475

Is in conformity with the European Directives:

LVD Directive 2014/35/EU

EMC Directive 2014/30/EU

ROHS Directive: (EU) 2015/863 amending 2011/65/EU

This product is also in conformity with the following standards:

EN 60335-1: 2012/A15:2021

EN 60335-2-29: 2021/A1:2021

EN 62233: 2008

EN IEC55014-1:2021; EN IEC55014-2: 2021

EN IEC61000-3-2:2019/A1:2021;

EN 61000-3-3:2013/A2:2021

Responsible of the technical file: Mr Olivier PATRIARCA

Cugnaux, 20/11/2024

Philippe MARIE/PDG

9. WARRANTY

The manufacturer guarantees the product against defects in material and workmanship for a period of 2 years from the date of the original purchase. It can be extended by one year if the user subscribes to website of myswap. The warranty only applies if the product is for household use. The warranty does not cover breakdowns due to normal wear and tear.

The manufacturer agrees to replace parts identified as defective by the designated distributor. The manufacturer does not accept responsibility for the replacement of the machine, in whole or in part, and/or ensuing damage.

The warranty does not cover breakdowns due to:

- insufficient maintenance.
- abnormal assembly, adjustment or operations of the product.
- parts subject to normal wear and tear.

The warranty does not extend to:

- shipping and packaging costs.
- using the tool for a purpose other than that for which it was designed.
- the use and maintenance of the machine done in a manner not described in the user manual.

Due to our policy of continuous product improvement, we reserve the right to alter or change specifications without notice. Consequently, the product may be different from the information contained therein, but a modification will be undertaken without notice if it is recognized as an improvement of the preceding characteristic.

READ THE MANUAL CAREFULLY BEFORE USING THE MACHINE.

When ordering spare parts, please indicate the part number or code, you can find this in the spare parts list in this manual. Keep the purchase receipt; without it, the warranty is invalid. To help you with your product, we invite you to contact us by phone or via our website:

+33 (0)9.70.75.30.30

<https://services.swap-europe.com/contact>

You must create a "ticket" via the web platform.

- Register or create your account.
- Indicate the reference of the tool.
- Choose the subject of your request.
- Describe your problem.

Attach these files: invoice or sales receipt, photo of the identification plate (serial number), photo of the part you need (for example: pins on the transformer plug which are broken).



10. PRODUCT FAILURE

WHAT TO DO IF MY MACHINE BREAKS DOWN?

If you bought your product in a store:

- Make sure that your machine is complete with all accessories supplied, and clean! If this is not the case, the repairer will refuse the machine.
- Go to the store with the complete machine and with the receipt or invoice.

If you bought your product on a website:

- Make sure that your machine is complete with all accessories supplied, and clean! If this is not the case, the repairer will refuse the machine.
- Create a SWAP-Europe service ticket on the site: <https://services.swap-europe.com> When making the request on SWAP-Europe, you must attach the invoice and the photo of the nameplate (serial number).

Contact the repair station to make sure it is available before dropping off the machine.

Go to the repair station with the complete machine packed, accompanied by the purchase invoice and the station support sheet downloadable after the service request is completed on the SWAP-Europe site

Please keep your original packaging to allow for after-sales service returns or pack your machine with a similar cardboard box of the same dimensions.

For any question concerning our after-sales service you can make a request on our website <https://services.swap-europe.com>

Our hotline remains available at +33 (9) 70 75 30 30.



11. WARRANTY EXCLUSIONS

THE WARRANTY DOES NOT COVER:

- Start-up and setting up of the product.
- Damage resulting from normal wear and tear of the product.
- Damage resulting from improper use of the product.
- Damage resulting from assembly or start-up not in accordance with the user manual.
- Periodic and standard maintenance events.
- Actions of modification and dismantling that directly void the warranty.
- Products whose original authentication marking (brand, serial number) has been degraded, altered or withdrawn.
- Replacement of consumables.
- The use of non-original parts.
- Breakage of parts following impacts or projections.
- Accessories breakdowns.
- Defects and their consequences linked to any external cause.
- Loss of components and loss due to insufficient screwing.
- Cutting components and any damage related to the loosening of parts.
- Overload or overheating.
- Poor power supply quality: faulty voltage, voltage error, etc.
- Damages resulting from the deprivation of enjoyment of the product during the time necessary for repairs and more generally the costs related to the immobilization of the product.
- The costs of a second opinion established by a third party following an estimate by a SWAP-Europe repair station
- The use of a product which would show a defect or a breakage which was not the subject of an immediate report and/or repair with the services of SWAP-Europe.
- Deterioration linked to transport and storage*.

* In accordance with transport legislation, damage related to transport must be declared to carriers within 48 hours maximum after observation by registered letter with acknowledgement of receipt. This document is a supplement to your notice, a non-exhaustive list.

Attention: all orders must be checked in the presence of the delivery person. In case of refusal by the delivery person, it you must simply refuse the delivery and notify your refusal.

Reminder: the reserves do not exclude the notification by registered letter with acknowledgement within 72 hours.

Information:

Thermal devices must be wintered each season (service available on the SWAP-Europe site). Batteries must be charged before being stored.



BUILDER SAS

32 rue Aristide Bergès - Z.I. du Casque - 31270 Cugnaux - France

Made in PRC